

Yuma County Fair and Rodeo



Royalty Handbook

Table of Contents

Who is Yuma County Fair & Rodeo Queen	pg. 3
Qualities of a contestant	pg. 3
Contest Rules and Regulations	pg. 3
General	pg. 3
Contest Judging	pg. 5
Contest Reigning Patterns	pg. 24
Borrowers Agreement & Deposit	pg. 7
Duties of Yuma County Queen and LIW	pg. 7
Required Appearances	pg. 7
Public Relations	pg. 7
Queen's Banquet and Visiting Counties Day	pg. 8
Pictures	pg. 8
Expenses	pg. 8
General Budget Estimated Reimbursement Breakdown	pg. 9
Fundraising/Sponsorship	pg. 10
Scholarship Program Policy	pg. 11
Code of Conduct	pg. 12
Meetings	pg. 13
Appearances	pg. 13
Parents/Chaperones	pg. 14
Boyfriends	pg. 14
Alcohol/Tobacco	pg. 14
At appearances Rules	pg. 15
Rodeo's & Parades	pg. 15
Truck & Trailer	pg. 16
Grievances & Grounds for Dismissal	pg. 16
Committee Contact Information	pg. 17
Rough Timeline of Events	pg. 18
Code of Conduct and Handbook Signature Page	pg. 19
Queen & LIW Waiver	pg. 19
Copies of Insurance and Driver's License	pg. 20
Truck & Trailer Agreement Copy	pg. 21
Emergency Contact page	pg. 23
Horsemanship Contest Reining Patterns	pg. 24

Who is “Yuma County Fair and Rodeo Queen”:

The Yuma County Fair and Rodeo Queen (YCFRQ) are the ideal western American young woman. She symbolizes the youth of Yuma County who wishes to promote Yuma County, Yuma County agriculture, and the sport of rodeo.

What are the qualities of a Yuma County Fair and Rodeo contestant?

The Yuma County Fair and Rodeo Queen contest strives to find a representative who will act, speak, and dress in a manner consistent with the prestige the title deserves. This young woman would have the following qualities:

1. Desire to be a leader in her community and promote the county’s great farming and ranching heritage.
2. Love of horses and everything they represent.
3. Desire to act as the official representative of the Yuma County Fair and Rodeo to the public, including the following traits:
 - a. Unexcelled sportsmanship
 - b. High moral and ethical character
 - c. Careful and humane treatment of animals
 - d. Understanding the sport of Rodeo and local agriculture
 - e. Ability to speak intelligently, with dignity, and sincerity to explain and “sell” the Yuma County Fair and Rodeo and Yuma County agriculture; even to someone who knows nothing about them.
 - f. Willingness to travel across Northeast Colorado, and sometimes beyond, to promote Yuma County & its agriculture.
4. Interest in furthering her chosen career through higher education and special training.
5. Appreciation for the rewards she receives and the value of the many sponsors and volunteers of the program.

Contest Rules and Regulations

General:

The Yuma County Fair and Rodeo Queen serve as the official host for the Yuma County Fair and Rodeo and is also a representative of the Yuma County Cattlemen’s Association and Yuma County Agriculture. The Queen Committee strives to make the contest a memorable experience and in turn asks for full cooperation. The committee is confident

that the Lady-in-Waiting (LIW) that is chosen each year will represent this county and the program in a grand manner and will carry those traits into her Queen year. The contest will be intense and demanding, and we ask for your total concentration. If there is anything the Queen Committee can do for any contestant to prepare, please ask.

1. The Queen Committee has complete authority over the entire YCFR LIW contest and all events and activities that involve the contestants.
2. Contest eligibility requirements are:
 - a. Must be single, never married, and/or not pregnant.
 - b. You must be **16 years** of age by Dec.31st the year of tryout and not over **21 years** of age. Exception requests must be submitted in writing prior to January 1st of the fair year.
 - c. You must sign the entry application and have a parent or guardian. Also sign the entry application under 21 years of age.
 - d. Must sign the liability of waiver.
 - e. Must agree to comply with all contest rules as established by the Queen Committee with the possibility of disqualification for infractions.
 - f. May not have held any other County Queen titles.
 - g. Must sign borrower's agreement at tryout's and give \$100 deposit for Contestant sash during tryout's (which will be returned on the ending day of fair, if returned intact/without damage)
 - h. Must live in Yuma County, exception:
 - i. Lives slightly outside of Yuma County, however, goes to school in Yuma County. Family works in Yuma County, and if they did 4-H/FFA projects shown at Yuma County Fair.
3. All problems or complaints are to be referred immediately to the Queen Committee. Breaking any rules and/or conduct unbecoming the YCFRQ by a contestant may lead to disqualification from the contest and/or program.
4. All applications must be postmarked seven days prior to the contest or hand delivered to the Yuma County Commissioners Office by the deadline date/time.
5. The contest will be held the day prior to the opening of the Yuma County Fair. Contestants will be judged on speech and interview, poise and personality, horsemanship, written test and a typed written essay.
6. Each contestant must bring her own horse and riding equipment, which may be borrowed.
 - a. A tie-down may be used.
 - b. Spurs may be worn at the discretion of the contestant.
 - c. No stallions may be used.

- d. Horses and Contestants must be prepared to carry a flag and to switch horses with other contestants as part of the competition.
7. All contestants will then be required to assist the current YCFR Queen and LIW while handing out ribbons at shows and making other appearances during the fair.

Contest Judging:

All judges are carefully selected and are invited to judge because of their ability and expertise. Judges will not reside within Yuma County; exceptions will be last minute cancelations and extenuating circumstances. If an exception occurs, it will be the decision of the Coordinators and Liaisons aka Queen Committee to decide the next course of action for judges. Judges are instructed to visit all contestants as much as possible. The judges for this contest are instructed that the type of girl the YCFR Queen Committee seeks is one who exemplifies:

- Sincerity
- Integrity
- Intelligence
- High moral standards
- Maturity
- Public speaking ability
- Knowledge of the Yuma County Fair and Rodeo and Yuma County agriculture
- Knowledge of current events

Contestants will be judged in four parts – (Speech & Interview, week of fair judging) (General, Poise & Personality) (Horsemanship) (Application, Essay, Letters of Recommendations, Written Test)

There will be ABSOLUTELY NO COACHING OR TRAINING of either contestant or horse during the competition. Any failure to comply with the rules of the pageant may result in the disqualification of the contestant.

Speech & Interview: The aim of this division is to select the girl who is rated the highest in intelligence, common sense, ability to speak in public, projection, and showmanship. Every applicant will be required to give a 5–7-minute prepared speech on “**How can I promote Yuma County and its agriculture?**” During the judging, each applicant will interview a panel of judges to determine their knowledge of agriculture and rodeo and their duties and responsibilities as a representative of Yuma County.

Horsemanship: The aim of this judging is to select the girl who is rated the highest in riding ability, mounting, and dismounting, balance, and position. The Committee reserves the right to ask contestants to switch horses during any part of the contest. Also,

contestants must be prepared to carry a flag while horseback. Only one horse may be used during the tryout. This section will consist of a queen run, carrying flag, basic rail and cattle work and knowledge of your horse, equipment, and care. The judges may ask for additional exercises if needed for them to make an accurate decision. Be prepared to switch horses at the discretion of the judges. A general reining pattern will be presented 10 minutes before this portion of the contest begins for contestants to study and execute.

Reining patterns are chosen from (reining patterns in the back of the handbook)

- AQHA (<https://www.aqha.com/reining>)
 - Pattern 1
 - Pattern 7
- CSU Show Patterns (<https://co4h.colostate.edu/program-areas/horse-resources/show-patterns/>)
 - Pattern K- Level II and III Reining (NRHA Pattern A)
 - Pattern B- Level 1 Reining
 - Pattern A- Level 1 Reining
 - Pattern 2- Level III and IV (NRHA Pattern 2)

General, Poise & Personality: The aim of this judging is to select the girl who is rated the highest in posture, poise, fashion sense, conversational ability, genuine interest in other people, sense of humor, and overall happy outlooks. Every applicant must adhere to a dress code during the judging and throughout the fair. For the day of judging, applicants must wear blue jeans, a white long-sleeved collared shirt, and a black cowboy hat for the horsemanship portion and a dress outfit for the interview and speech. Other western collared shirts and cowboy hats are allowed for the remainder of the fair events. All clothing must be clean and fitted. Points from this section will be split into two parts. Most of the points are given for the day of the contest and based on appearance, attitude, and personality and the other points to be given by “undercover” judges, watching the applicants as they aid the Queen and Lady-in-Waiting throughout the fair.

Application/Essay/Recommendations/Written Test: Every applicant must submit at least a 500-word typed essay on, “Why are rodeo queens so important to the sport of rodeo? How will you be able to make a suitable candidate to be the next Lady-in-Waiting?” These will be judged on grammar, spelling, and creative thinking/content. Grammar and Spelling will be judged separately by a licensed teacher. There also needs to be two letters of recommendation to go with the typed essay and the application. Be prepared for a written test. Suggested study material would be Rodeo and the rules, 4-H/FFA Rules, know Yuma County and its history. Suggested websites for studying but not limited to:

yumacounty.net

goldenplains.extension.colostate.edu/programs/4-h-youth-development/yuma-county-4-h/

<https://prorodeo.cld.bz/2022-PRCA-Rule-Book>

The contestant will need two letters of recommendation to accompany the essay and the application. Letters of recommendations **CANNOT** come from family members.

Borrowers Agreement & Deposit:

Please be aware that starting Aug. 2019, contestants, and their guardian (if under 21) will need to sign a borrower's agreement to receive their contestant's sash for tryouts. Sashes will be handed out on the morning of the LIW judging contest and will be returned prior to the LIW announcement. Upon receipt of a sash on, there will need to be a \$100 deposit in check or cash which will be given back once the sash is received by the Queen Committee. If the sash is not returned within 7 days of post fair, the money will be deposited into the Fair Queen Account.

Duties of the Yuma County Queen and Lady-in-Waiting:

The Yuma County Fair and Rodeo royalty are remarkably busy throughout the year with many different events and appearances. They must carry out all duties assigned to them. The official reign begins on Eckley Old Settlers Day and runs for one year.

1) **Required Appearances:** The Queen and LIW will be reimbursed \$40.00 each for up to seven "out of county appearances" and \$30.00 each for up to seven "in county appearances" minimum requirement (6 out of county, 6 in county)

- **Yuma County Fair & Rodeo**
- **Old Threshers**
- **Eckley Old Settlers Day**
- **Wray Daze**
- **Yuma County Cattleman's Auction**
- **Yuma County Cattleman's Year End Banquet**
- Other appearances can be arranged as their schedule allows.
- Travel to neighboring county fairs is encouraged, along with other official appearances such as **National Western Stock Show**
- Possible but not limited to out-of-county appearances are Grover, Elizabeth, Logan County Fair, Kit Carson County, Phillips County, Eastern Colorado Round-up, Brush Fair, Greeley Stampede, Estes Park, Kiowa County, Adam's County, Boulder County
- If either the Queen or LIW are unable to appear at a required event, prior notification to a committee member is required.

2) Public Relations:

- It is the duty of the YCFR Royalty to promote Yuma County, Yuma County Agriculture and Yuma County Fair, and Rodeo.
- To encourage people to attend Yuma County Fair and Rodeo.

- i) You need to be prepared with materials to hand out and be versed in all aspects of both the YCFR and the County of Yuma as a whole.
- ii) This may include radio spots, make appearances, and hand out materials to crowds.
- It is the responsibility of the YCFQ and LIW to submit **All Events** they attend to local newspapers (as a News Item), which includes Yuma Pioneer (info@yumapioneer.com) and Wray Gazette (wraygazette@plainstel.com) and the Fair Queen Facebook page.

3) Queen's Banquet/Luncheon/Dinner:

- The Queen and LIW will work together on a luncheon for visiting queens attending the Yuma County Fair Parade and Rodeo.
- A Queens barrel race will be added to the County Events during the fair. Queen and LIW will work with the coordinators to decide on the sponsored prizes for this event. Queens barrel race will be open to all current or past royalty, visiting or in-county.

4) Pictures:

- YCFRQ and LIW will submit their official photo for the coming year to the Queen Committee by March 1st each year for the fair book. This deadline is solid and is needed for the Fair Book picture entry and to update the website.
- Past Queen Picture Boards are in the concession building at the fairgrounds and will be updated each year. The current Queen will be responsible for contacting Jim Powel in Yuma, CO to get this official picture taken for the Queen Board. Picture needs to be done no later than Wray Daze each year.

Financial Policy

Yuma County Fair and Rodeo Royalty follow the Yuma County financial policy and audit process. The queen's account is considered and outside account under the Board of County Commissioners to allow the Queens to be Tax-Exempt. The account is managed and run by the Queen Coordinators, which includes the dispersal of payments from the checking account. Money will be moved to and from the savings account as needed. A budget will be proposed to the committee at the beginning of every calendar year. Once approved, it will be updated in the handbook for that year. The committee has decided that any payments over \$1,300 will require committee approval before payment is made.

- **General Budget Estimated Break-down:** (this is also how much will be reimbursed unless prior authorization by committee)

	Year 2025	Year 2026
Register Opening Yearly Balance	\$ 161.85	\$ 6,202.93

Max Reimbursement to Queens	2025 Expenses	2026 Budget
Fuel	\$ 42.90	\$ 300.00
Hotel	\$ -	\$ 500.00
Queen Out of County Appearances (\$40x7)	\$ 210.00	\$ 280.00
LIW Out of County Appearances (\$40x7)	\$ 150.00	\$ 280.00
Queen In County Appearances (\$30x7)	\$ 105.00	\$ 210.00
LIW In County Appearances (\$30x7)	\$ 105.00	\$ 210.00
Queens Dinner Decor & Visiting Queen Gifts	\$ 940.79	\$ 1,200.00
Queens Dinner Food	\$ 1,081.14	\$ 1,200.00
General Expenses	\$ 643.62	\$ 700.00
Clothing (Parade/Rodeos)	\$ 443.27	\$ 600.00
Flyer's/Advertisement/ Marketing	\$ 305.07	\$ 400.00
Halloween Candy	\$ 116.22	\$ 150.00
Incidentals	\$ 50.00	\$ 250.00
	\$ 4,193.01	\$ 6,280.00

Coordinators Budget	2025 Expenses	2026 Budget
Saddle	\$ 2,235.00	\$ 1,300.00
Chaps/ Sash	\$ 1,409.00	\$ 1,500.00
Buckle	\$ 105.00	\$ 110.00
Crown/Spurs	\$ 159.00	\$ 300.00
Jacket- New Crowned LIW	\$ 100.00	\$ 100.00
Judging Contest/Tryouts	\$ 589.75	\$ 700.00
Pickup Lease	\$ 800.00	\$ 800.00
Office Supplies	\$ 390.40	\$ 600.00
Newspaper Thank You's/ Pickup Thank You's	\$ 325.50	\$ 550.00
Rodeo/Parade Supplies	\$ 676.11	\$ 800.00
Trailer/Pickup Vinyl	\$ 932.00	\$ 1,100.00
Cajun Boil	\$ 3,113.71	\$ 3,500.00
Queen/LIW Gifts	\$ 219.20	\$ 350.00
Fair (Concessions, food, drink, etc.)	\$ 197.63	\$ 300.00
Princess Program	\$ 198.91	\$ 400.00
	\$ 11,451.21	\$ 12,410.00
Total Expenses	\$ 15,644.22	\$ 18,690.00

Income		
---------------	--	--

Commissioners Contribution	\$	1,200.00	\$	1,200.00
Cattlemen's Contribution	\$	1,200.00	\$	1,200.00
Cajun Boil Fundraiser	\$	5,925.00	\$	6,000.00
Princess Program	\$	580.00	\$	600.00
Sponsorships	\$	12,780.30	\$	13,000.00
Total Income	\$	21,685.30	\$	22,000.00

Year End Remaining

\$6,202.93

(Financial Policy/Budget approved by Queen Committee 02/26/2026)

- Yuma County Fair Queens are Tax Exempt. Everyone will be provided with the tax-exempt ID certification information to use when purchasing items and getting sponsorships. When you are seeking reimbursement for materials or items bought on your own dime, please be aware that if it is listed in the above budget, it will be reimbursed. If it is outside the above budget, you will need to get prior approval from the coordinator to receive reimbursement. If you do not use or supply the business you are purchasing items from our Tax-Exempt information, you will **NOT** be reimbursed for the tax, only the approved items themselves.
- The coordinator will work with the Yuma Conty Finance Officer to submit receipts, monthly statements, and other documentation for yearly audit. The coordinator will submit paperwork on April 1, July 1, Oct 1, Jan 1 (final year end submission) to the Finance Officer to assist the Auditors in keeping up to date.
- The Queen and LIW will be reimbursed for travel for 7 out of county events, 5 in county events. You must submit a list of places attended with dates in a spreadsheet format to the coordinator for reimbursement.
- Queen is required to present Coordinators with a monthly updated reimbursement spreadsheet and receipts to help keep budget on track.
- 10% of the remaining balance in the checking account at the end of each Calander year will be transferred to the saving's account before scholarship fund will be dispersed.
- For all reimbursements, receipts need to be given to the Queen Coordinator or mailed to:
 - Michelle Smith 9359 State Highway 59, Yuma CO 80759

Fundraising/Sponsorships:

- Every year the Queen and LIW will need to fundraise money to supplement the general fund to cover their expenses. This can be done through door-to-door fundraising, gift baskets auctioned at the Cattleman Banquet, annual Cajun boil, etc.

- As of 2023, the Royalty program has implemented a 3-year Commitment form. This commitment form allows a sponsor to sign up for 3 years of sponsorship, which allows them to have their logo sponsored on the side of the trailer in vinyl. If a sponsor chooses to make the 3-year commitment, please have them fill out the paperwork. They will have the option to receive a yearly invoice which the coordinator will send out at the beginning of January. However, both ladies will still need to stop at each sponsor to introduce themselves and thank them for their sponsorship in person.
- A thank-you note is **REQUIRED** for all people or organizations who contribute to the program, no matter the donation. Alternativity - A large thank you can also be done instead at the end of the Queen's year in both newspapers and Facebook. This will be at the discretion of the queen which method she would like to go with.
- The Yuma County Royalty is a non-profit organization, so there should not be more funds than necessary for the required equipment from the approved budget listed above. Any funds that are left over at the end of the year must be put towards equipment that can be used by upcoming royalty.
- There still will be out-of-pocket expenses such as clothing, hats, horse tack, etc. If funds allow and enough money is raised, this can be reimbursed out of the Queen Account.
- Both the current Queen and LIW will need to attend a commissioner meeting in November or December with their Coordinators to introduce themselves, present yearly proposed agenda, and to request their yearly contribution to the program.
- Both the current Queen and the LIW will need to attend a Cattlemen's meeting along with their coordinators, normally in January, of their year to go over proposed agenda for the year, gather information for the Banquet and Calcutta, introduce themselves and to request their yearly contribution to the program.
- As of 2025, the Queen Program will host a yearly Cajun Boil Fundraiser. The date of the fundraiser will be decided by that year's Queen.
- The Yuma Count Royalty program will also host a yearly Princess Program during the fair.

Scholarship Program Policy

Yuma County Fair & Rodeo Royalty (YCFRR) will establish in 2026 and fund an annual scholarship to be awarded to the outgoing Fair Queen of Yuma County.

Purpose

- YCFRR will provide financial assistance to those who are improving their lives by furthering their education and commitment to their community.

Eligibility

- Those attending any post-secondary educational institution will be eligible. Eligible institutions include universities, colleges, technical schools, trade, and vocational institutions. Only the outgoing Fair Queen will be eligible for the scholarship each year.

Application Process

- All applicants will apply for the Yuma County Fair and Rodeo Lady-in-Waiting Contest. That contest consists of an application, written essay, 2 letters of recommendation, interview process, horsemanship portion and general contestant duties during fair that year. At the end of fair, the next years Lady-in-Waiting will be crowned. That individual will be eligible for the scholarship at the end of her Queen year.

Scholarship Amount

- The amount to be awarded will be awarded a minimum of \$500 scholarship and up to 30% of the remaining Fair Queen checking account money raised that year. The 30% will only apply after all required bills are paid for that year, and that year's budget requirements are met. If you go over budget, you are exempt from the scholarship.

Distribution

- The Scholarship will be paid directly to the recipient's school. The funds may be used for tuition, room, board, books, or materials. A letter of acceptance or proof of enrollment from an educational institution is required. This letter must be submitted to the coordinators. The letter must include the school's information

including address and where the check should be sent (ex. Attn. Financial Office). The scholarship will be sent at the beginning of January after the budget has closed for the year. You will also need to provide the coordinators with a bio about yourself, the school you are attending, and the field of study so the coordinators can put out a news item about the scholarship you received.

Code of Conduct

Behavior:

YCFR Royalty should exhibit high standards and lady-like behavior in every situation. Regarding attitude, she should represent a pleasant personality and be willing to help in any way that will better promote Yuma County and its agriculture. It is her responsibility to answer questions about rodeo, the county, and all aspects of the people and industries she represents. The YCFR Royalty is constantly in the public eye. It is always of utmost importance for her to look at her best. Her appearance not only reflects how she feels about herself but also about the title.

- Abstain from illegal and immoral behaviors; this includes both the internet and in person.
- Abstain from using cell phones and other devices while in your official role.
- Fully participate in scheduled activities
- Show respect for other property and privacy rights.
- Refrain from child, animal, physical, and verbal abuse
- Accept personal responsibility for behavior.
- Even if you are in a bad mood, wear a smile no matter what.

Meetings:

- Regular monthly meetings with the Queen Committee will be required to keep the year running smoothly and efficiently.
- A 1st meeting with the newly appointed LIW and YCFQ will be required shortly after the Fair to start preparations for the next year. This meeting of parents/Guardian of both LIW and YCFRQ is required.

Appearance:

- YCFR Royalty should be willing to listen and take advice pertaining to wardrobe, make-up, hair, etc.
 - Standard Required clothing: The royalty will be in felt hat, crown, long-sleeved shirt, jeans, belt, sash, jeans or long skirt and boots at all appearances.
 - The committee is aware that we are in the 20th century and wardrobes have evolved and changed. When you find an outfit that is appropriate for western attire and are in doubt if you may wear something, please contact the coordinators for approval.
 - Hair should be clean and tidy; consider curling it as well.
 - Make-up should be appropriate for the event and attire.
 - Hats and boots should be clean.
 - Clothing items should be clean and pressed with no wrinkles.
 - During your reign you may be recognized while not in your official capacity, so it is especially important to think about your appearance anytime you are in public.

Parents/Guardians:

- While we encourage parents to be supportive of their daughter, their actions should always be in the background.
- Helping your daughter get ready for performances and events is highly encouraged and welcomed. Please remember that once the event starts, the coordinators are responsible for helping the girls at this point regarding the needs of the event.
 - We highly encourage the parents to take this time to watch, videotape, take pictures and route for the girls.
 - This is the perfect time to observe how much the girls have achieved and grown during the year.
- Parents are asked to remember that this program is for their daughter and is about their daughter. Please allow your daughter to be the best young woman she can be.
- Parents are also reminded that their actions have a direct reflection on their daughter in the public eye.
- YCFR Royalty should have a chaperone at all events. If a Queen Committee member is unavailable, then a parent is recommended as a chaperone. The chaperones will be there to see to needs and to escort the Royalty to and from functions in a safe manner.
- Any infraction will be reported to the committee who will then take appropriate action.

Boyfriends:

- Applicants must be single, never married, had marriage annulled, have no children, and must not marry or get pregnant during her reign.
- Boyfriends or significant others will not be permitted to show affection or other similar behavior at any sanctioned event while on duty or off duty as you are representing YCF&R.
- They are welcome to attend functions when appropriate for support or assistance when needed.

Alcohol & Tobacco:

- Alcohol and tobacco are prohibited for the Queen and Lady-in-Waiting while in an official role and while in public (whether in official role or not)
- Please be very vigilant that you are being watched 24/7 365 by everyone. The committee is not the boss of your personal life choices; however, if a complaint is made and verified about drinking/tobacco or drug use and the direct reflection of the Queen Program has been brought to question, it will be grounds for dismissal.
 - This includes but is not limited to DUI, DWAI, MIP, pictures, written communications, etc.

General “At Appearance” rules:

- Invitations: When an invitation is received to attend a rodeo, luncheon, etc., it is expected to RSVP immediately with a yes or no answer. When unable to attend a Thank, you note, you should be sent in appreciation for the invitation. When able to attend, she should offer help in any way possible.
- Be always in full attire and be ladylike in your behavior and manners and if anything, unusual occurs please notify the committee immediately.
- Interact with as many people as possible and be especially cordial to other rodeo royalties.
- Allow enough time to arrive at any location on time. If it is a rodeo, arrive with plenty of time to take care of your horse and make yourself ready.
- Always be ready to answer questions about Yuma County and be prepared with a short speech in case you are asked to speak. Also, carry promotional items to give out about your fair and rodeo. Your goal is to bring as many spectators to Yuma County Fair and Rodeo as possible.

Rodeos & Parades:

- Upon arriving at any rodeo or parade you should contact a committee member or host royalty and talk with them about the schedule and ask if any assistance is needed.
- Go prepared for all events prepared with both girl names, coordinator information, that you are from Yuma County, Co, and dates of Yuma County Fair & Rodeo.
- Talk with the host royalty on how they are handling the Grand Entry and Introductions, such as “run in run out,” “line-up,” etc.
- Stay out of the way of any contestant, stock contractor, or employee and always make sure you are ready to go at any time when your name is called.
- Always make sure your horse is cared for and has proper feed and water and keep your area and stall clean. This is a direct reflection on you, fellow royalty, and the Yuma County Fair & Rodeo. Failure to leave the area in which you and your horse were kept better than when you arrived will be grounds for dismissal if a grievance is made from the county in which you are visiting.

Truck & Trailer:

- The YCFR Royalty will have the use of a donated pick-up and County owned horse trailer.
- At least one adult chaperone (parent/guardian/queen coordinator) will be required on all trips where the truck and trailer are in use.
- No one under the age of 18 years of age will be allowed to drive the truck and/or haul the trailer. A committee member, parent or guardian will be required to attend events to drive the truck and trailer if royalty is under 18 years of age.
- Other family members or friends will need to make other arrangements for travel as only the current royalty and chaperone are permitted in the truck while traveling.
- No personal use of the donated truck or trailer is permitted. This will be grounds for dismissal if not followed.
- Only individuals confirmed by the queen's coordinates may drive the pick-up and trailer. They must first have a current driver's license and vehicle insurance. Queen Coordinator must have a copy of all individuals who will be driving and/or hauling the truck/trailer.
- (See copy of example agreement in back of the handbook)

Grievances & Grounds for Dismissal

Grievances:

- The Queen Committee will act as a grievance committee and will always be available to receive any type of grievance that may occur.

- All grievances or changes must be filed in writing with the committee at the earliest possible time.
- If a grievance cannot be settled by the committee involved a final decision shall be that of the Yuma County Commissioners and Cattlemen Liaison.

Dismissal:

- Conduct not to keep up with these standards will not be tolerated. Violation of items listed will result in consequences for the participants.
- Consequences may include removal at the individual’s expense and without refund, restitution or repayment of any damages, and forfeiture of all gifts (saddle, breast collar, buckle, tiara, any money reimbursed to the individual from the royalty budget)
- Two “strikes” will be allowed for minor mistakes, but illegal activity will be grounded for immediate dismissal. A “strike” may consist of anything deemed unacceptable by the committee that is addressed in this document. Any individual receiving a “strike” will get written notice of the incident.

Contact Information/ Queen Committee

Queen Coordinator - Michelle Smith Michellesmith010@gmail.com Cell- 970-630-5868

Queen Asst. Coordinator - Kaci Porter fairqueen_07@hotmail.com Cell- 720-985-0162

Cattlemen’s Liaison – David Schaffner david@wrayfeedandbean.com Cell- 970-630-4807

Fair Board Liaison – Justin Crossland justin_crossland@hotmail.com Cell- 970-630-3063

Commissioner Liaison – Scott Weaver sweaver@co.yuma.co.us Cell- 970-630-7611

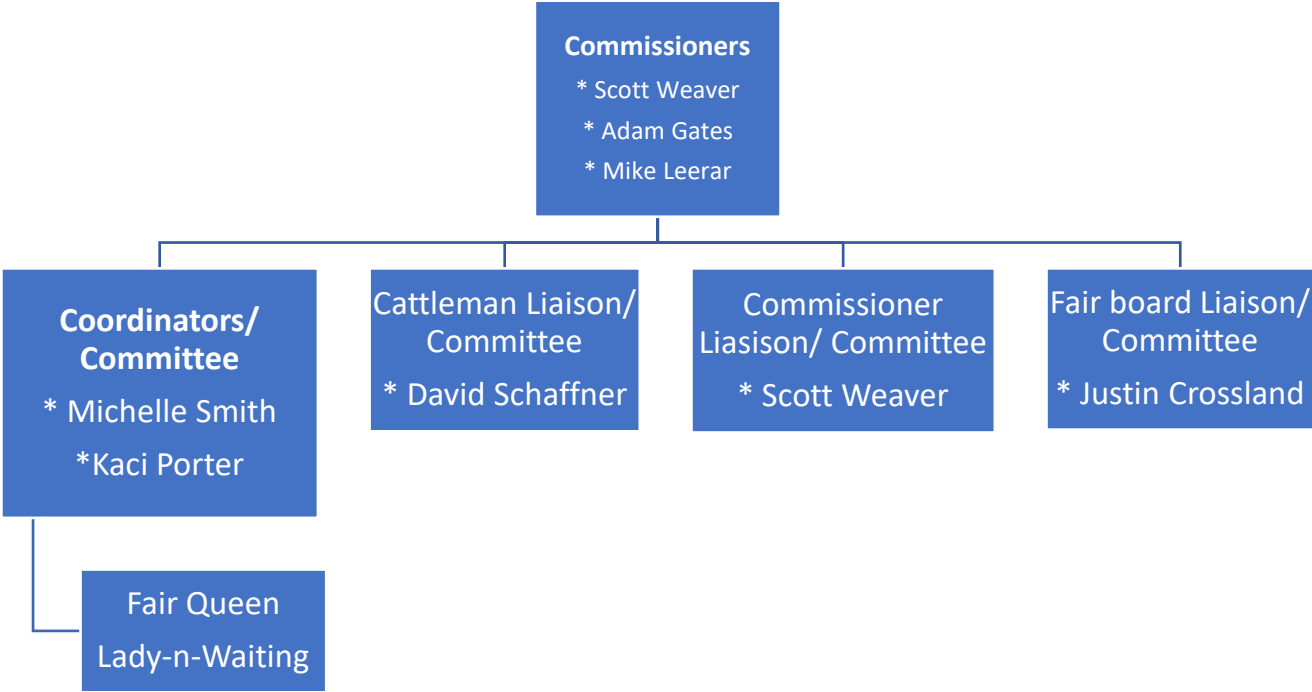

Rough Timeline of Upcoming year: (Subject to changes)

Aug:

- Thank you sent out to all sponsors or Large. Thank you to newspapers and Facebook by the retiring queen.

Sept:

- Eckley Old Settlers Days
- Old Threshers, Yuma CO
- Get LIW chaps, sashes, saddle & Jacket etc. ordered

Oct/Nov:

- Start looking for emails about NWSS.
- Get pics taken and flyers made.
- Senior Citizen spaghetti supper
- Commissioners Meeting/Budget

Dec:

- Fundraising for the current year.
- Events: Wray parade of lights
- You should have all your equipment and materials ready for the new year.

Jan/Feb/March/April:

- NWSS
- Cattlemen's Calcutta, make baskets.
- Plan & execute fundraiser (Cajun Boil).
- Start looking online for local fair info to get a schedule started.
- Make sure Truck and Trailer are ready: should talk with Bonanza & County office to pick up June 1

May/June:

- Cattlemen Banquet
- Make and send out invites for Fair to visit queens.
- Find local events to go to such as daycares, nursing home
- Start preparing for Fair Queen Luncheon
- Tryout practice for contestants

July:

- Going to rodeos and events as much as possible
- Tryout Practices for contestants
- Wray Daze

Aug:

- FAIR!!!!
- Still have many events available

This confirms that you have read and agree to the terms of the Code of Conduct and YCFRR Handbook for the Yuma County Fair and Rodeo Royalty Program.

I, _____ agree to these terms and conditions during my reign as Yuma County Fair and Rodeo Royalty.

Print Name: _____

Signature: _____

Signature of Parent Guardian (for minor): _____

Date of Acceptance: _____

Yuma County Fair Queen/Lady-in-Waiting Waiver

I hereby for myself, agree to abide, by all rules and regulations pertaining to the Yuma County Fair & Rodeo Queen and Lady-in-Waiting Program- I assume all liabilities and responsibility for any loss, accident, or injury, whether as to property or person, arising in any way out of the operations or activities of your committee or management, in any event or part of any performance of while in, on or about the premises of the Yuma County Fairgrounds. I hereby release the right, title, and claim of any photographs or videos that may be taken by the committee for their use. I certify that I know the rules of the contest and the YCFRQ and LIW program and agree to abide by them. The undersigned has read the foregoing release carefully and fully understands its meanings. Parents signing with their daughter agree they have also read the rules, regulations, and handbook. Parents agree; they fully understand its meaning.

Candidate's Signature: _____ Date _____

Candidate Print Name: _____

If Contestant in under 21 years of age, Approved and attested by:

Signature of Parent or Guardian: _____ Date: _____

Print Parent or Guardian Name: _____

Attached Driver's License (attach below)

Attached Copy of Vehicle Insurance Card (attach front and back below)

Queen Pick-up & Trailer Agreement

This Pick-up & Trailer Agreement made this _____ day of _____, 20__ between Yuma County Commissioners/Queen Coordinators and _____ (Queen) & _____ (Lady-in-Waiting) organized and existing in Yuma County.

THE PARTIES AGREE AS FOLLOWS:

1. **Leased Pick-up.** Subject to the terms and conditions of the Lease between Yuma County Commissioners and Bonanza Ford, Inc of Wray, CO 80758. (Vehicle) _____ (Color) _____ (VIN#) _____ (License Plate) _____
2. **Leased Amount.** Yuma County Commissioners/Queen Program shall pay \$ _____ for the complete lease of the Pick-up from Bonanza. Queen Program is responsible for acquiring the sponsorship for this lease and paying Commissioners \$ _____ by the start of Fair.
3. **Insurance.** As described in the lease from Bonanza Ford, Inc- (for use for the fair queen summer of 2022, if anything should happen to the pick-up then the Commissioners Insurance will be responsible for damages.)
4. **Program Rules for Usage.** A pickup and horse trailer will be provided for the use of the Yuma County Fair Queen and Lady in Waiting.
 - One adult chaperone **MUST** accompany the YCFQ and LIW as they travel together to all appearances.
 - An adult must be 21 years of age, parent/guardian, or coordinator.
 - Other family members will need to make alternate arrangements for travel.
 - No personal use of the donated trailer or pick-up will be allowed.
 - A copy of a current Driver's License/Vehicle Insurance must be provided to the coordinator from Queen, LIW, and parents- all parties that would be allowed to drive/haul the pick-up and queen trailer.
 - In the case of an accident or emergency, notify Emergency Services/Fire Department/Police depending on the situation. As soon as possible, notify Coordinator Michelle Smith or Assistant Coordinator Kaci Porter if Coordinator is unreachable. Your Coordinator will be responsible for guiding you through the next steps and for communicating up the chain of command.
 - Absolutely **NO ALCOHOL OR TOBACCO** used in/on/on/on/or around the Pick-up/Trailer by anyone. If there is an outside the queen program individual causing problems or coming in contact with, the Pick-up/Trailer, contact Coordinator Michelle Smith to handle the situation and dissolve the situation.
 - You will be provided with security devices (i.e., hitch receiver pin lock, trailer hitch coupler lock, trailer tongue lock)- these devices must be used to protect against theft.

Signature Page of Acceptance Truck & Trailer Agreement

_____ Queen	_____ Sign/Print	_____ Date
_____ Lady-in-Waiting	_____ Sign/Print	_____ Date
_____ Queen Parent	_____ Sign/Print	_____ Date
_____ Queen Parent	_____ Sign/Print	_____ Date
_____ LIW Parent	_____ Sign/Print	_____ Date
_____ LIW Parent	_____ Sign/Print	_____ Date
_____ Queen Coordinator	_____ Sign/Print	_____ Date
_____ Queen Asst. Coordinator	_____ Sign/Print	_____ Date



YC Royalty Emergency Contact Sheet

Name:	DOB:
Cell Phone:	
Address:	

Name:	Relationship to Queen:
Cell Phone:	Home or Work:
Address:	

Name:	Relationship to Queen:
Cell phone:	Home or Work:
Address:	

Allergies: Prescription & Environmental

Pertinent Medical History

Prescription Medications

Queen Coordinator: Michelle Smith
 Asst. Queen Coordinator: Kaci Porter

Cell Phone: 970-630-5868
 Cell Phone: 720-985-0162

Yuma County Commissioners: Scott Weaver, Mike Leerar, Adam Gates

Address: 310 Ash Street, Suite A Wray, CO 80758

Phone: 970-332-5796 Administrative Assistant: Brandi Ritchy

REINING PATTERN I

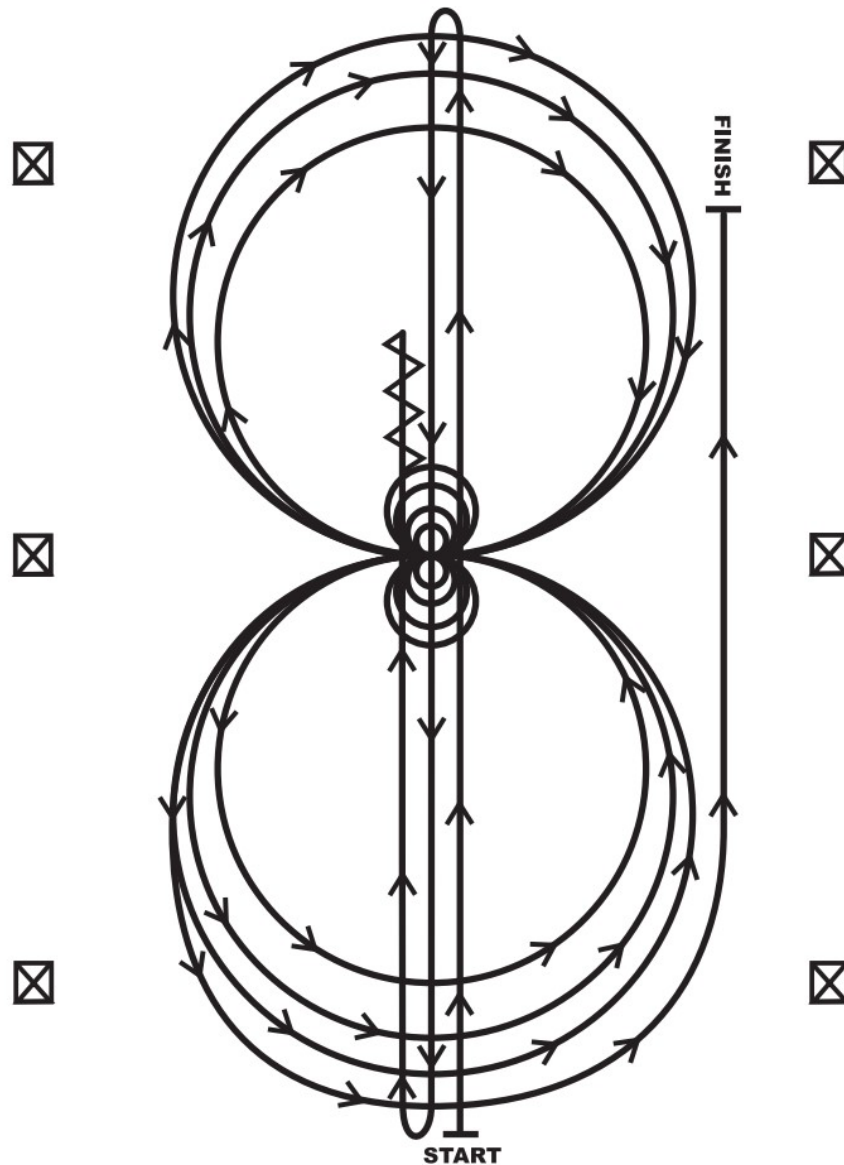

1. Run at speed to the far end of the arena past the end marker and do a left rollback—no hesitation.
2. Run to the opposite end of the arena past the end marker and do a right rollback—no hesitation.
3. Run past the center marker and do a sliding stop. Back up to center of the arena or at least ten feet (three meters). Hesitate.
4. Complete four spins to the right. Hesitate.
5. Complete four and one-quarter spins to the left so that horse is facing left wall or fence. Hesitate.
6. Beginning on the left lead, complete three circles to the left: the first circle large and fast; the second circle small and slow; the third circle large and fast. Change leads at the center of the arena.
7. Complete three circles to the right: the first circle large and fast; the second circle small and slow; the third circle large and fast. Change leads at the center of the arena.
8. Begin a large circle to the left but do not close this circle. Run straight up the right side of the arena past the center marker and do a sliding stop at least twenty feet (six meters) from wall or fence. Hesitate to demonstrate the completion of the pattern.

Revised 01-2021

REINING PATTERN 7

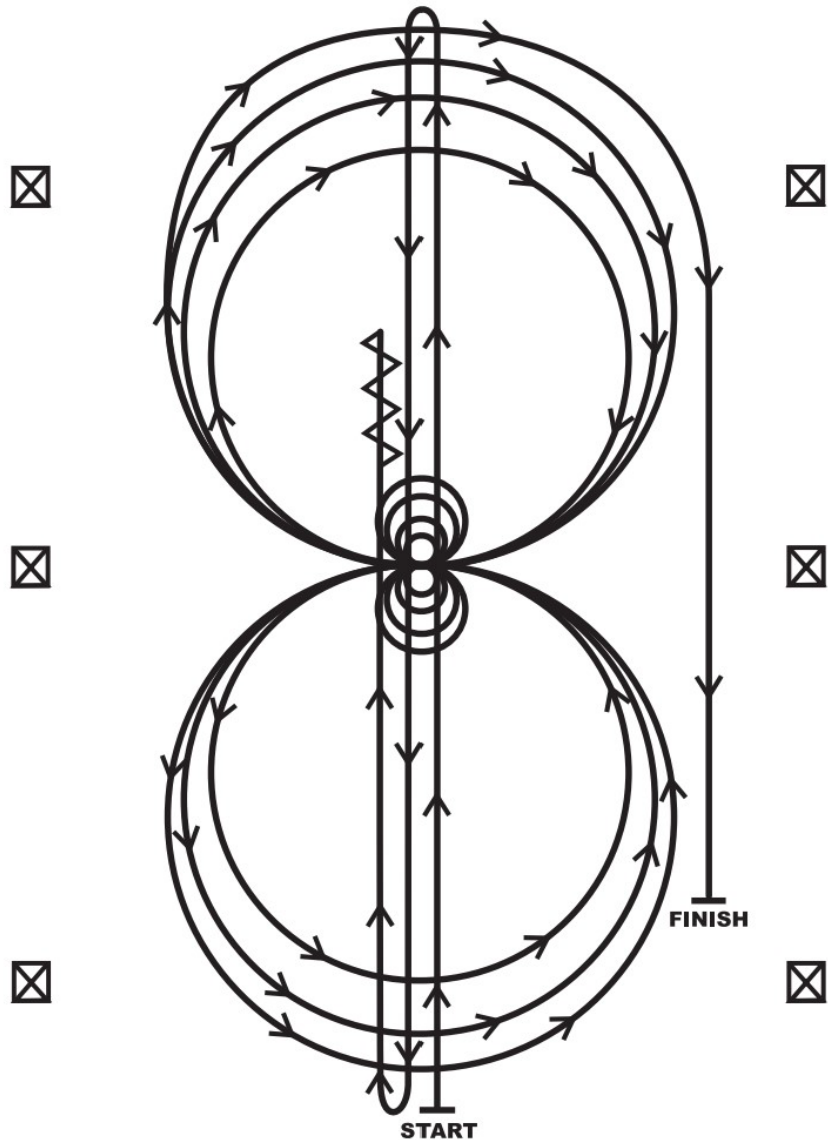

1. Run at speed to the far end of the arena past the end marker and do a left rollback—no hesitation.
2. Run to the opposite end of the arena past the end marker and do a right rollback—no hesitation.
3. Run past the center marker and do a sliding stop. Back up to the center of the arena or at least ten feet (three meters). Hesitate.
4. Complete four spins to the right. Hesitate.
5. Complete four and one-quarter spins to the left so that horse is facing left wall or fence. Hesitate.
6. Beginning on the right lead, complete three circles to the right: the first two circles large fast; the third circle small and slow. Change leads at the center of the arena.
7. Complete three circles to the left: the first two circles large fast; the third circle small and slow. Change leads at the center of the arena.
8. Begin a large circle to the right but do not close this circle. Run straight down the right side of the arena past the center marker and do a sliding stop at least twenty feet (six meters) from the wall or fence. Hesitate to demonstrate completion of the pattern.

Revised 01-2021

174. Pattern K – Level II and III Reining (NRHA Pattern A)

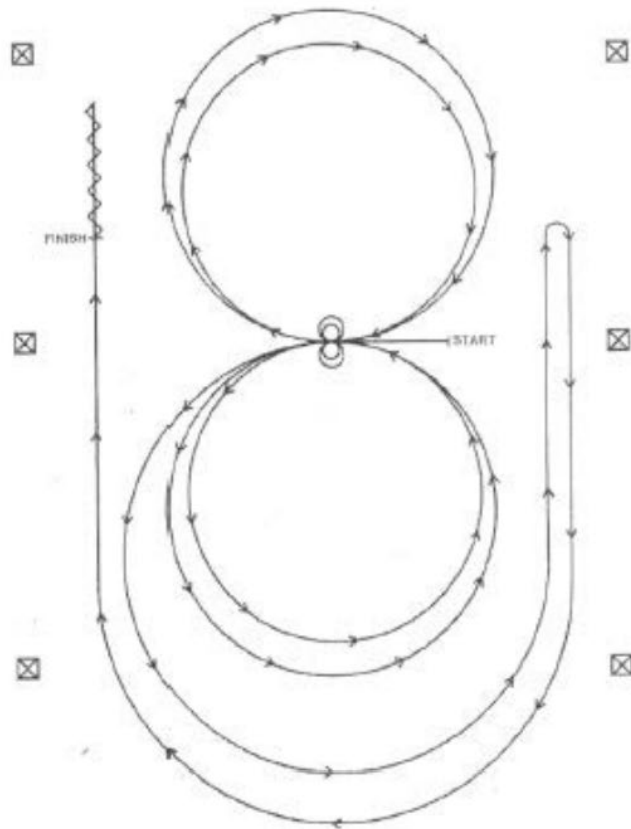

Horses may walk or trot to the center of the arena. Horses must walk or stop prior to starting the pattern. Beginning at the center of the arena facing the left wall or fence.

1. Beginning on the left lead, complete two circles to the left. Stop at the center of the arena. Hesitate.
2. Complete two spins to the left. Hesitate.
3. Beginning on the right lead, complete two circles to the right. Stop at the center of the arena. Hesitate.
4. Complete two spins to the right. Hesitate.
5. Beginning on the left lead, go around the end of the arena, run down the right side of the arena past center marker, stop and roll back right.
6. Continue around the end of the arena to run down the left side of the arena past the center marker. Stop. Back up.

165. Pattern B - Level I Reining

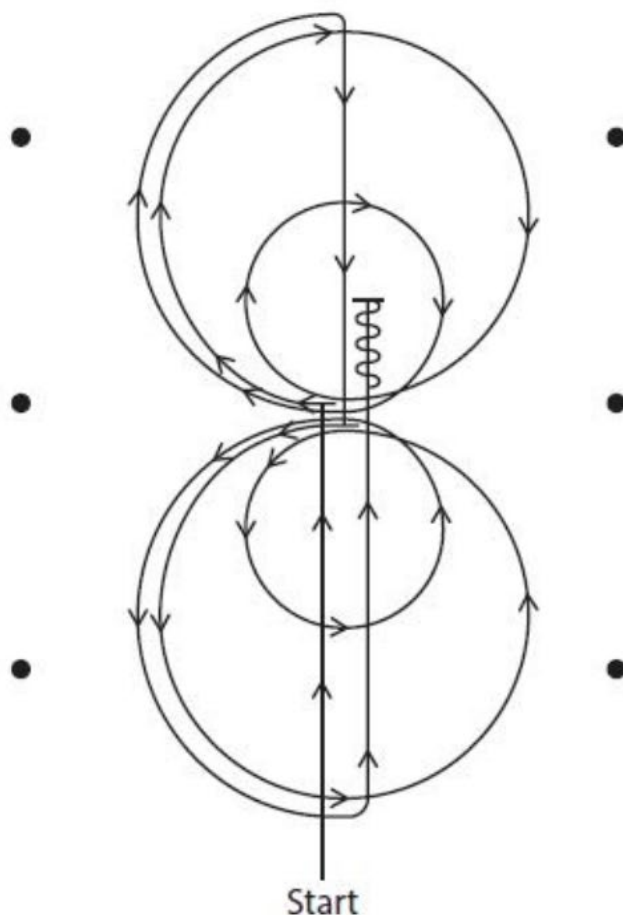

Back:  Jog:  Lope: 

Proper execution of this pattern requires Level I Advancement skills. All stops are balanced.

1. Lope to center of arena and halt at center marker.
2. 90 degree turn to the left.
3. Lope a large circle to the right followed by a small circle to the right.
4. Continue around previous large circle, at the top of the circle, run down the middle to the center marker and halt.
5. 90 degree turn to the right.
6. Lope a large circle to the left followed by a small circle to the left.
7. Continue around previous large circle, at the top of the circle, run down the middle past the center marker, halt and back at least ten feet.

164. Pattern A – Level I Reining

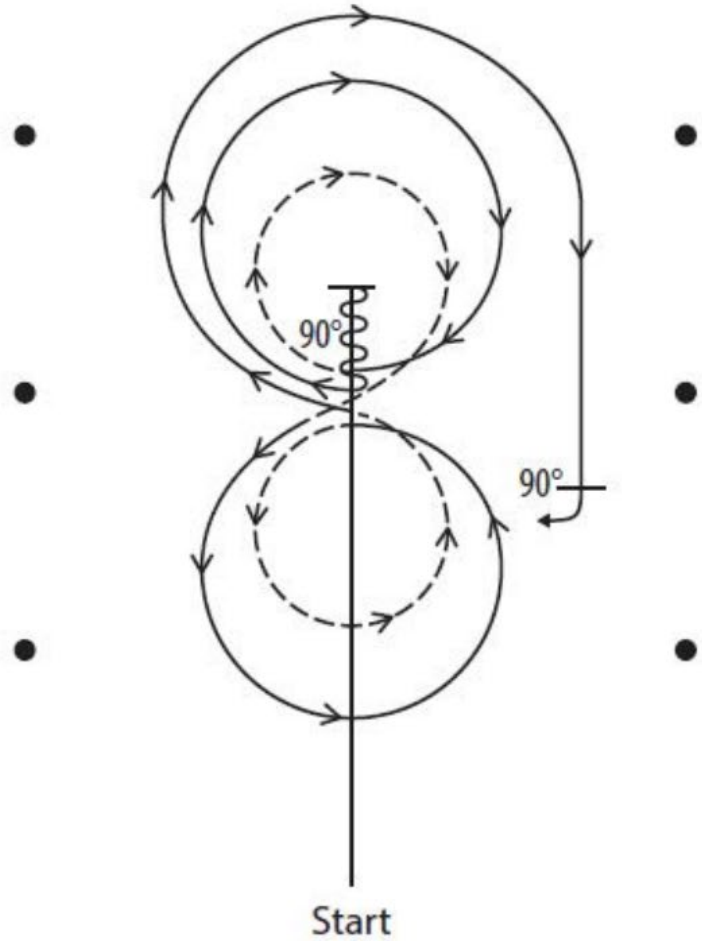

Back:  Jog:  Lope: 

Proper execution of this pattern requires Level I Advancement skills. All stops are balanced.

1. Lope at least ten feet past center marker. Stop & back up to the center, or at least ten feet.
2. 90 degree turn to the left, hesitate.
3. Lope large circle right.
4. Trot small circle right.
5. Lope large circle left.
6. Trot small circle left.
7. At center, pick up right lead, begin a large circle to the right but do not close this circle. Run straight down the right side of the arena staying at least twenty feet from the wall or fence past the center marker, stop.
8. 90 degree turn to the right.

178. Pattern 2 – Level III and IV Reining (NRHA Pattern 2)

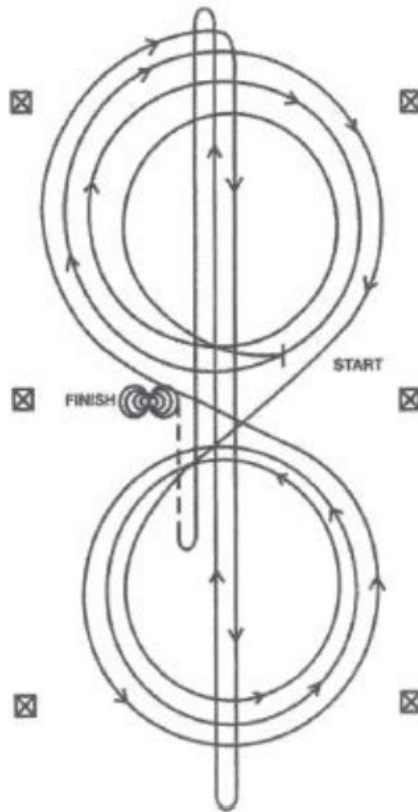

Begin at the center of the arena facing the left wall or wall or fence. Horses may walk or jog to the center of arena on walk in patterns. However, they must walk or stop prior to starting pattern.

1. Beginning on the right lead, complete three circles to the right: the first circle small and slow; the next two circles large and fast. Change leads at the center of the arena.
2. Complete three circles to the left: the first circle small and slow; the next two circles large and fast. Change leads at the center of the arena.
3. Continue around previous circle to the right. At the top of the circle, run down the middle to the far end of the arena past the end marker and do a right rollback – no hesitation.
4. Run up the middle to the opposite end of the arena past the end marker and do a left rollback – no hesitation.
5. Run past the center marker and do a sliding stop. Back up to the center of the arena or at least ten feet. Hesitate.
6. Complete four spins to the right. Hesitate.
7. Complete four spins to the left. Hesitate to demonstration of the pattern.

Rider must drop bridle to the designated judge.